

# Dutchess

Bakers' Machinery Company, Inc.

A subsidiary of Superior-Lidgerwood-Mundy Corp

Item No.

---

## Model DUT/S-100

100 Liter Floor Model Spiral Mixer



### Standard Features:

- ◆ 100 Liter Stainless Steel Mixing Bowl
- ◆ 84 lbs. of flour
- ◆ 132 lbs. of dough
- ◆ Bowl dimensions 23.6" x 13.9"
- ◆ 2 speeds Spiral and Bowl drive
- ◆ 2 timers to program the working cycle
- ◆ Stainless Steel Security Guard & Spiral Hook
- ◆ Drive Motor: 4.75 HP, 3/4 HP Bowl Motor
- ◆ Electricity: 208/230V / 3 phase
- ◆ NET Weight 870 lbs.
- ◆ Dimensions 43" x 25.6" x 42.5"
- ◆ Industry Leading, 3-Year Limited Parts Warranty
- ◆ 1-Year Full Parts and Labor Warranty
- ◆ Heavy-duty construction & powerful 2-motor system



Dutchess Bakers' Machinery Company

302 Grand Avenue, PO Box 39

Toll Free: 800-777-4498

Phone: 715-394-4444

E-mail: [sales@dutchessbakers.com](mailto:sales@dutchessbakers.com)

Web: [www.dutchessbakers.com](http://www.dutchessbakers.com)

# Model DUT/S-100 Floor Model Spiral Mixer

**D = 43"**

**W = 25.6"**

**H = 42.5"**

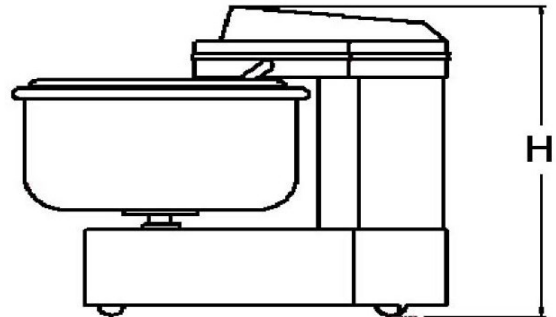
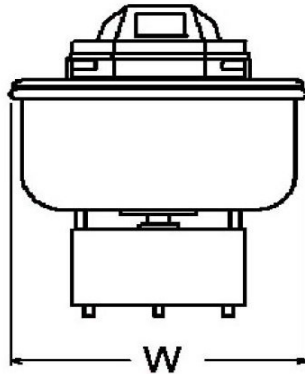
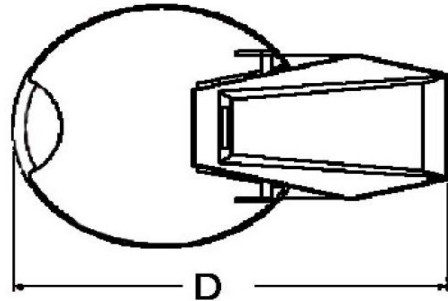

## **Electrical:**

4.75 hp Heavy Duty Motor 208-230v / 60hz / 3-phase, 3/4 hp Bowl Motor

Overload Relay to Protect Motor - Auto Shut-Off when Bowl Guard Opened.

Emergency Stop Button for Safe Operation

## **Dimensions:**

25.6" Wide x 42.5" High x 43" Depth

## **Weight:**

870 lbs. Net Weight, 1000 lbs Shipping Weight.

## **Features:**

- ◆ 100 Liter Stainless Steel Mixing Bowl - Bowl dimensions 23.6" x 13.9"
- ◆ Reversible Mixing Action
- ◆ 2 speeds Spiral and Bowl drive
- ◆ 2 timers to program the working cycle
- ◆ Stainless Steel Security Guard & Spiral Hook
- ◆ Bowl motor: 4.75 HP
- ◆ Heat Treated Enamel Coating Resistant to Rust, Dents & Scratches.

## **Warranty:**

- ◆ 3-Year Limited Parts
- ◆ 1-Year Standard Parts and Labor

DUTCHESS BAKERS' MACHINERY COMPANY, INC. 302 GRAND AVENUE, SUPERIOR, WI 54880-0039

TOLL FREE: 800-777-4498 - PH: 715-394-4444 - FAX: 715-394-2406