

Dutchess

Bakers' Machinery Company, Inc.

A subsidiary of Superior-Lidgerwood-Mundy Corp.

*A United States of America Manufacturer
Since 1886*

Item No. _____

Model CA31-PF10-CD-R-DUT
Half Size Portable Proof/Holding
Cabinet with Dough Divider Mount



- ~ Constructed of high tensile aluminum.
- ~ Temperature adjustable to 160 degrees.
- ~ Heat/Proof unit totally independent for easy removal and cleaning. Three separate heating elements for proper air circulation and quick recovery times.
- ~ Pan Capacity 10 max on 1-1/2" centers.
- ~ In door Digital Thermometer.
- ~ 5" x 1-1/2" High Tech non-marking swivel casters (two with brakes).
- ~ Dough Divider mounting bracket welded to top accepts Dutchess Models BMIH & LD-626 manually operated Dough Dividers.
- ~ Clear Door for easy view of product.
- ~ Magnetic latch on door.

NSF NSF (National Sanitation Foundation Int'l.)

UL UL (Underwriter Laboratories)

ASSOCIATE MEMBER
MAFSI
Manufacturers' Agents for
the Food Service Industry

Dutchess Bakers' Machinery Co.
302 Grand Avenue, PO Box 39
Superior, WI 54880

ISO 9000:2001 COMPLIANT

Toll Free: 800-777-4498
Phone: 715-394-4444
Fax: 715-394-2406
sales@dutchessbakers.com
www.dutchessbakers.com

MODEL CA31-PF10-CD-R-DUT

Half Size Portable Proof/Holding Cabinet with Dough Divider Mounting Bracket
(Shown with Dutchess Model BMIH Dough Divider mounted on top)

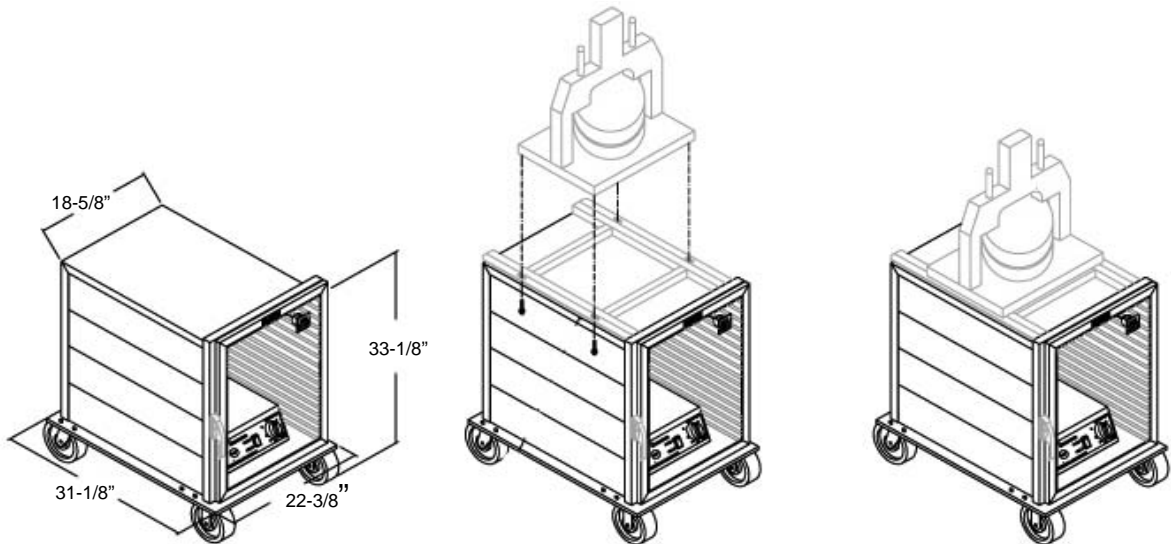

Cabinet Dimensions:

Dimensions: Width: 22-3/8" Depth: 31-1/8" Height: 33-1/8"

Shipping Wt.: 82 lbs.(39.6 kg) **Net Wt.:** 63 lbs (36 kg) **Shipping Class:** 85 **FOB:** 54880

Shipping Dimensions: 37.37" x 22.38" x 31.25"

Electrical: 120v / 60 hz / 1-phase, 15 amp circuit 3-prong plug

Heat/Proof unit is totally independent for easy removal and cleaning. Comes standard with three heating elements for proper air circulation and quick recovery times.

Thermometer: In door Digital Thermometer

Construction: High tensile aluminum

Top Mounting Bracket: Fits Dutchess Models BMIH and LD-626
(holes tapped to exact dimensions)

Standard: Temperature adjustable to approximately 160 degrees.

Clear door with magnetic latch.

5" x 1-1/4" High Tech non-marking Casters with swivel plate (2 w/brakes)

Pan capacity:10 max on 1-1/2" centers. (lip hung)

Dutchess Bakers' Machinery Company Inc., 302 Grand Avenue, Superior, WI 54880-0039

Toll Free: 800-777-4498 ~ Ph: 715-394-4444 ~ Fax: 715-394-2406

sales@dutchessbakers.com ~ www.dutchessbakers.com

