

# Dutchess

*Bakers' Machinery Company, Inc.*

*A subsidiary of Superior-Lidgerwood-Mundy Corp.  
A United States of America Manufacturer Since 1886*

Item No. \_\_\_\_\_

## DUT/TXM-15

MANUAL DOUGH PRESS

TORTILLA & PIZZA (Square Platen)

### Manually Operated Dough Press

Great for: **Flour Tortillas, Corn Tortillas & Pizza**

#### Features Include:

- o 15" x 15" dual heated platens can press, flatten and/or par bake tortillas in seconds.
- o Top & Bottom platens heat from Off to 450°F
- o Heated platens flatten dough faster or can be used without heat for cold pressing.
- o Top platen swings away for easy loading and unloading of dough.
- o Full range dough thickness adjustment.
- o Easy to use open and close handle.
- o Optional non-stick coated upper & lower platens.
- o Square platens flatten dough into all sizes up to 15" diameter in quantities up to 4 at a time.
- o 220 volt / 50-60hz, 3100 watts, 15 amps.
- o 16-1/2" wide x 15-1/4" high x 24" deep.
- o ETL & ETL sanitation listed to NSF criteria.
- o Works for either flour or corn tortillas, pizza dough and flat breads.



**Dimensions:** 16.5" (41.91 cm) x 15.25" (38.74 cm) x 24" (60.96 cm)

**Weight:** Press only: 68 lbs., (30.84 kg)

**Electrical:** 220 Volts / 50-60 Hz / 1-Phase, 3,100 Watts, 15 Amps, 15-6P NEMA Plug on 220v

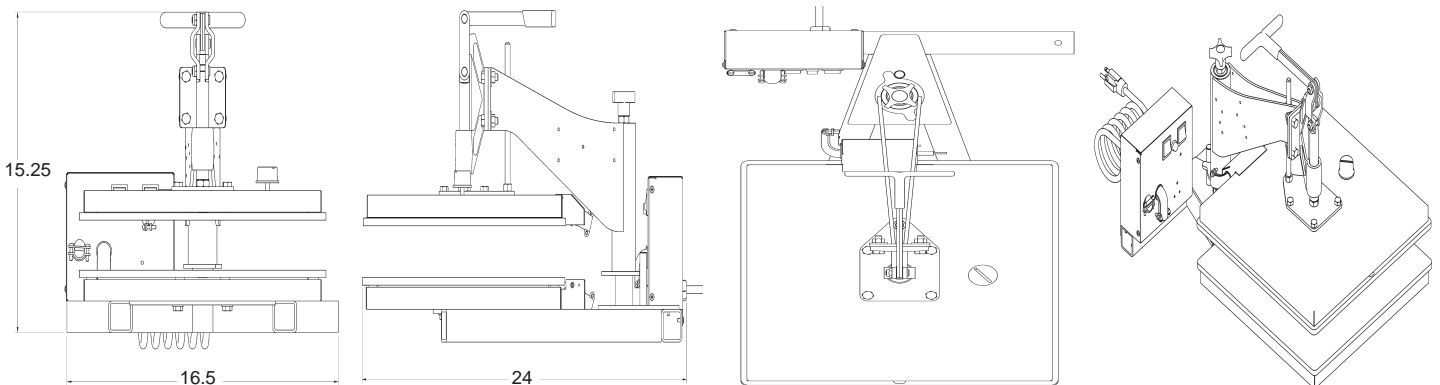

ASSOCIATE MEMBER  
**MAFSI**  
Manufacturers' Agents for  
the Food Service Industry

**Dutchess Bakers' Machinery Co.**  
302 Grand Avenue, PO Box 39  
Superior, WI 54880

**ISO 9000:2001 COMPLIANT**

Toll Free: 800-777-4498  
Phone: 715-394-4444  
Fax: 715-394-2406  
sales@dutchessbakers.com  
www.dutchessbakers.com

© 2009 Dutchess Bakers Machinery Company

