

Dutchess

Bakers' Machinery Company, Inc.

A subsidiary of Superior-Lidgerwood-Mundy Corp.

*A United States of America Manufacturer
Since 1886*

Item No. _____

Model BMIH - 36 (1-4 oz pieces)

Model BMIH - 18 (2-8 oz pieces)

Model BMIH - 9 (4-17 oz pieces)

Possible Combinations:

BMIH-36/18, BMIH-36/9, BMIH-18/9, BMIH-36/18/9

Manually Operated Dough Divider

Three machines in one Capability!

Interchangeable head assemblies in either 36, 18 and 9-part divisions allow fast accurate scaling of dough in weights ranging from:

36 pieces from 1 ounce up to 4 ounces each

- or -

18 pieces from 2 ounces up to 8 ounces each

- or -

9 pieces from 4 ounces up to 17 ounces each

When removed for cleaning or interchange, the entire head assembly can be placed into a sink or dishwasher for complete cleaning to a sanitary operating condition in just minutes per day.

Capable of dividing many types of dough including Yeast Raised, Cookie, Pie and even Ground Meat or Sausage for exact portion control.

Simple to operate - learn in just minutes!

Two year Warranty.

Lightweight and mobile when mounted to **Portable Stand** (P/N B4-436-0072) *not shown*

Made in the USA



NSF (National Sanitation Foundation Intl.)



USDA (United States Dept. of Agriculture)

ASSOCIATE MEMBER
MAFSI
Manufacturers' Agents for
the Food Service Industry

Dutchess Bakers' Machinery Co.
302 Grand Avenue, PO Box 39
Superior, WI 54880

ISO 9000:2001 COMPLIANT

Toll Free: 800-777-4498
Phone: 715-394-4444
Fax: 715-394-2406
sales@dutchessbakers.com
www.dutchessbakers.com

MODEL BMIH-36 ~ MODEL BMIH-18 ~ MODEL BMIH-9

(1 oz - 4 oz each)

(2 oz - 8 oz each)

(4 oz - 17 oz each)

Manually Operated Bench Model Dough Dividers

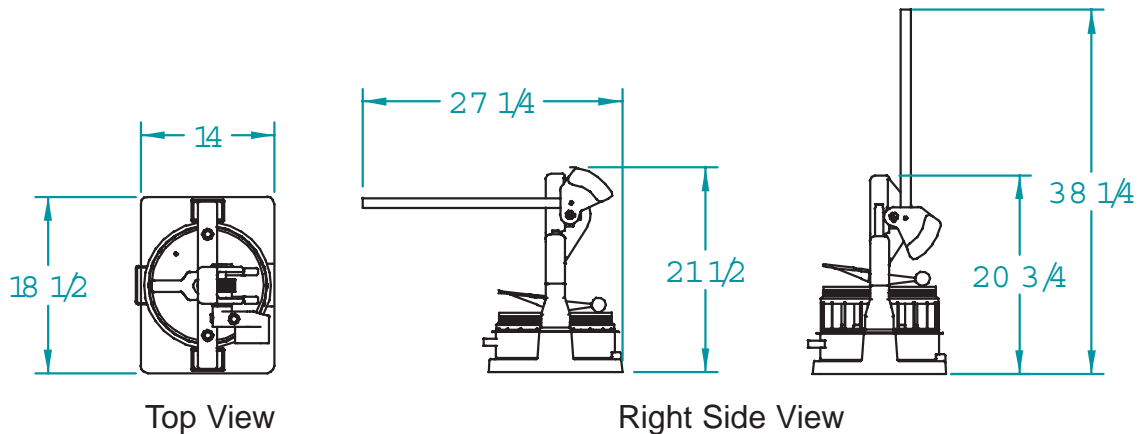

Machine Dimensions:

Width: 18-1/2" (46.99 cm) **Depth:** 14" (35.56 cm) **Height:** (incl. handle) 38-1/4" (97.15 cm)
Shipping Wt.: 88 lbs.(39.6 kg) **Net Wt.:** 80 lbs (36 kg) **Shipping Class:** 85 **FOB:** 54880
Shipping Dimensions: 15-3/4" x 19-1/2" x 25-1/2" (40 cm x 49.53 cm x 53.97cm)

Stand Dimensions:

Width:18-1/2" (46.99 cm) **Depth:** 23" (58.42 cm) **Height:** 28-1/2" (72.39 cm)
Stand Shipping Wt: 35 lbs (15.88 kg) **Shipping Dimensions:** 24" x 25-1/2" x 4-1/2"

Manually Operated Dough Divider (Bench Model)

Note: Must be mounted to a Bench, Table or optional **Portable Stand (P/N B4-436-0072)**

Mounting bolt hole pattern (on center): 16-7/8" x 12-1/2"

Standard: White Powder Coated Finish & (1) Stainless Steel Pan (P/N B4-149-0001)

Options: **Portable Stand** w/toe-lock casters & shelf (P/N B4-436-0072) (mounting hardware incl.)

Extra Stainless Steel Pans (P/N B4-149-0001).

IH-36 (36-part head when purchased separately).

IH-18 (18-part head when purchased separately).

IH-9 (9-part head when purchased separately).

Access owners manual and instructional videos on the Dutchess web site www.dutchessbakers.com

Dutchess Bakers' Machinery Company Inc., 302 Grand Avenue, Superior, WI 54880-0039

Toll Free: 800-777-4498 ~ Ph: 715-394-4444 ~ Fax: 715-394-2406
sales@dutchessbakers.com ~ www.dutchessbakers.com